



THE FRED D. PFENING COMPANY  
DEDICATED TO THE BAKING  
INDUSTRY SINCE 1919

## MODEL 300 PROOF BOX

### *Pfening Proof Boxes Feature...*

- Rugged corrosion resistant aluminum structural frame
- Sealed panels finished in natural aluminum and stainless steel
- Heavy duty solid-core doors with rugged latches and hinges
- Pfening Model B Digital Controller accurate to within ½% for both temperature and relative humidity
- Caster racks or monorail design
- Either Dry (steam injected) or Wet (air wash) conditioning units
- Any size or configuration to meet your production requirements
- Special designs to meet your individual needs
- BISCC Approved
- The Pfening Equi-Temp air conditioning system

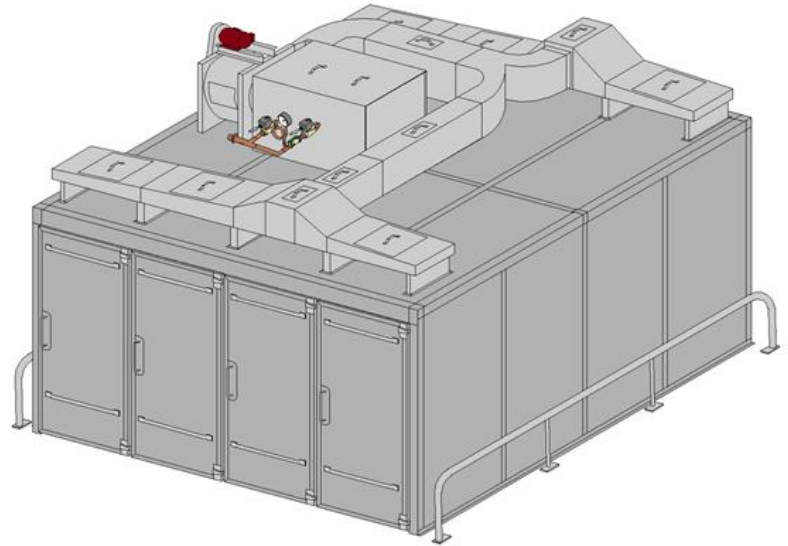

### *Pfening Equi-Temp™ Circulation The Gentlest Whirlwind Ever Created*

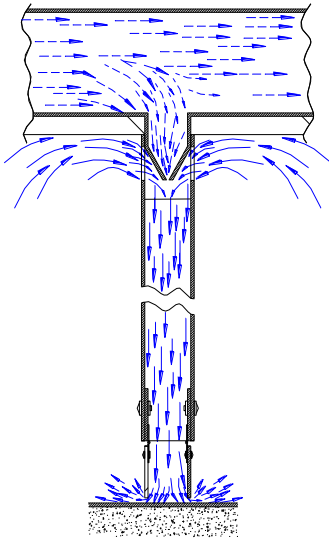

**Typical  
Downspout**

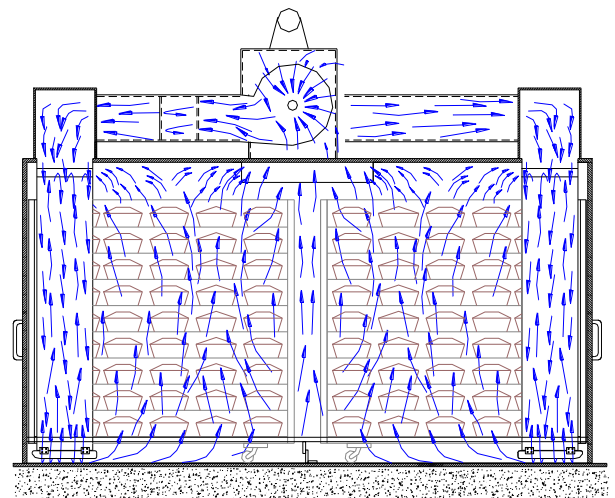
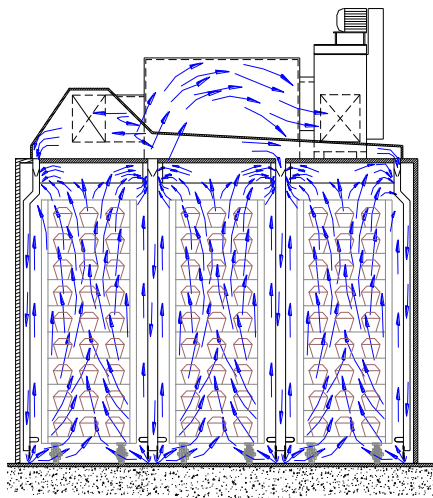

- Uniform temperature and humidity throughout the proof box
- Over 100 air changes per hour
- 43% newly conditioned air circulated through the radiator
- 57% recycled air drawn in at the ceiling
- Thermally isolated door frames and enclosure panels
- Air discharged at the floor – drawn off at the ceiling

THE FRED D. PFENING COMPANY  
MANUFACTURERS OF  
MATERIAL HANDLING, PROOFING,  
AND LIQUID METERING SYSTEMS  
Visit us at [www.pfening.com](http://www.pfening.com)

1075 WEST FIFTH AVENUE  
COLUMBUS, OHIO 43212  
PH. (614) 294-5361  
FAX (614) 294-1633  
email: [sales@pfening.com](mailto:sales@pfening.com)

#### SPECIFY TO ORDER:

- NUMBER OF LANES WIDE & RACKS DEEP
- RACK DIMENSIONS
- ELECTRICAL POWER SUPPLY VOLTAGE